

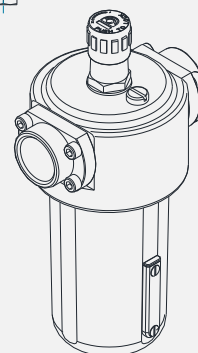

Lubrificatore a nebbia d'olio, dotato di rubinetto per la regolazione della quantità d'olio immessa nell'aria. È consigliato l'utilizzo di olii con viscosità inferiori alla ISO VG 22 (3°E).

Oil fog lubricator with a tap for regulating the oil rate nebulized into the air.

It is recommended to use an oil with a viscosity degree lower than ISO VG 22 (3°E).

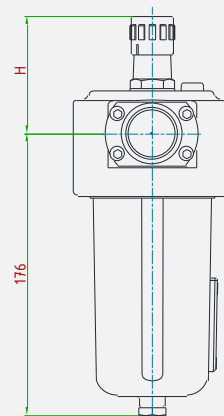
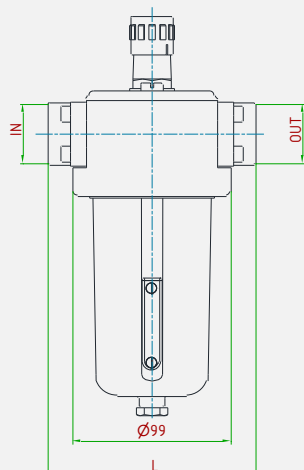

INLET PRESSURE	H (mm)
16 bar	74 (transparent tap)
30 bar	43 (metal tap)

IN/OUT connection	L (mm)
3/4" - 1"	130
1"1/4 - 1"1/2	241

CARATTERISTICHE PRINCIPALI MAIN FEATURES

COMPATIBILITÀ COMPATIBILITY	Aria compressa Compressed air
PRESSIONE DI ESERCIZIO MASSIMA MAX. INLET PRESSURE	30 bar (16 bar con visore trasparente / 16 bar max with oil level display)
ATTACCHI A PROCESSO IN/OUT CONNECTION	3/4"-F • 1"-F • 1"1/4"-F • 1"1/2"-F (GAS/NPT) • UNI EN 1092-1 • ASME B16.5
TEMPERATURA DI ESERCIZIO WORKING TEMPERATURE	-20°+60°C standard • da -60°C a +320°C a richiesta Standard -4°+140°F • available on request from -76°F up to +608°F
CAPACITÀ SERBATOIO OLIO OIL TANK CAPACITY	~500 CC
PESO WEIGHT	~ 2,1 kg ~4,6 lb
CERTIFICAZIONI CERTIFICATIONS	PED 2014/68/UE • EAC TR CU 010
MATERIALE CORPO E PARTI INTERNE INTERNALS AND BODY MATERIAL	Alluminio Aluminum
MATERIALE GUARNIZIONI SEALS MATERIAL	NBR • FPM • FVMQ • FFKM
KIT RICAMBIO SPARE PARTS KIT	O-ring, sfera per non ritorno O-rings, steel ball for check valve